

Coil-EEFL Tubes as Unrivaled Light Source with Small W_{coil} Over Solid Light Sources

Lyuji Ozawa

Japanese Government licensed Consultant in Science, Changping Qu, Beijing, China

Email address:

Rotsun4@hotmail.com

To cite this article:

Lyuji Ozawa. Coil-EEFL Tubes as Unrivaled Light Source with Small W_{coil} Over Solid Light Sources. *Science Research*.

Vol. 3, No. 4, 2015, pp. 230-239. doi: 10.11648/j.sr.20150304.21

Abstract: It has found that the active power consumption, W_{coil} , of the single coil-EEFL tube that is not related with the energy for the generation of the lights, reduces to below $0.1 W_{\text{act}}$ of the commercial CCFL tube with the same brightness of the original CCFL tube. The coil-EEFL tubes allow the parallel connection with the single external AC driving circuit. ΣW_{coil} of 10 coil-EEFL tubes goes down to $0.03 \Sigma W_{\text{act}}$. The figure of the merit of the lighting devices is quantum efficiency η_q . The η_q of the FL tubes is the astronomical number that is 10^{13} visible photons per unit volume (m^3) of Ar gas space per unit time (s) by one moving electron in the superconductive vacuum. The coil-EEFL tubes hold the unrivaled advantage with the power consumption and illuminance (lm m^{-2}) over the solid LED lamps that have only $\eta_q \approx 0.5$. A half of the injected electrons inevitably lose the energy by the Joule Heat.

Keywords: Green Energy, Power Consumption, Light Source, FL Tube, PDP

1. Introduction

The FL tubes have been studied for more than 80 years. The established technologies of the FL tubes however conceal the great latent advantages of the lighted FL tubes by the invalid evaluations and misinterpretations of the observed results. The latent advantages of FL tubes are below:

1. The coexistence of the disparate electric circuits [1, 2]. They are (a) the external AC driving circuit and (b) the internal DC electric circuit, notwithstanding the FL tube is operated with the visible AC driving circuit. The internal DC electric circuit in Ar gas space is invisible by the naked eyes, so that the presence has been overlooked in the past study. Then, it has been believed for 80 years that the lights in the FL tubes generate by the electrons from the external AC driving circuit [3, 4, 5, 6]. Recently it has revealed that the electrodes of the HCFL tubes never emit the thermoelectrons into the Ar gas space [7]. Consequently, the electrons in the external AC driving circuit never emit the light. The moving electrons from the cathode and anode of the internal DC electric power generator solely generate the lights from FL tubes.
2. The lights from the FL tubes generate from the excitation of Hg atoms by the moving electrons in the "superconductive vacuum between Ar atoms" in lighted

- FL tube [8]. The moving electrons in the superconductive vacuum do not lose the kinetic energy. Statistically, one moving electron in the lighted FL tube generates the astronomical number of 10^{13} visible photons per unit volume of Ar gas space (m^3) per unit time (s) that is the quantum efficiency η_q [8]. The figure of the merit of the lighting devices is the η_q . In the past, the study of the FL tubes, including PDP, ever reported η_q .
3. The commercial compact 20W-HCFL tube, that the positive column has the temperature at 60°C , emits the illuminance of $5700 (\text{lm m}^{-2})$ [9], corresponding to "2 x 10^{26} photons per second". The compact 20W-HCFL tube comfortably illuminates the furniture or desktop in a 17 m^2 room with the daytime scenery under the slightly overcast sky, which the human eyes adjust for 5 million years. The comfortable illumination of the room is made by the illuminance (330 lm m^{-2}). The required number of the FL tubes for the illumination of the given room has ever been calculated quantitatively. The illuminated room by one compact 20W-HCFL tube is calculated as $17 \text{ m}^2 \{5700 (\text{lm m}^{-2}) \times (330 \text{ lm m}^{-2})^{-1}\}$. Many commercial compact HCFL tubes do not light up with the illuminance of $5700 (\text{lm m}^{-2})$. They are around $2000 (\text{lm m}^{-2})$ with misunderstanding of the evaluation of the performance of the FL tubes by the luminous efficiency (lm W^{-1}).

4. Incorrect determination of the commercial FL tubes. The real active power consumption, W_{act} , of the external AC driving circuit has deliberately determined with the W_{tube} , neglected W_{drive} [10]. The actual W_{act} of the external AC driving device is given by $W_{act} = W_{tube} + W_{drive}$. The W_{act} of the 40W-HCFL tube is around 80 W with the ballast (chock coil) and 60 W with the inverter.
5. The antipollution of Hg on the earth by the scrapped FL tubes. The Hg atoms in FL tubes are liquid Hg. The real Hg pollution to the living life is made with the organic Hg compounds. Anyhow, the operation life of the FL tubes prolongs to longer than 10^5 hours by the application of the coil-EEFL tubes. If one uses the lamp for 10 hours per day, he may light up the lamp for 4×10^3 hours per year, and 4×10^4 hours for 10 years. If one takes the HCFL tubes, the operation life is less than 10^4 hours with the evaporation of the W-filament coil.

Those are the example of concealed latent advantages of the lighted FL tubes by the determination by the erroneous luminous efficiency (lm W^{-1}). The luminance from the lighted FL tubes is significantly influenced by the electric field, F_{phos} , from the electric charges on the phosphor screen [10].

At present, the LED lamps are on the market with the advertisement of the energy saving light source. We may calculate, as an example, the illumination of the room by the LED lamps as the scientific reality. The lighting mechanisms of the LED lamps quite differ from the FL tubes. The LED lamp emits a photon by the recombination of a pair of the electron and hole at the luminescence center. The number of the recombinations of the electrons and holes determines the number of the lighted photons. The number of the photons does not change with the applied voltage to the LED. For the generation of the lights by the LED lamp, the electrons and holes must inject into the LED lamp. The LED lamp is the solid device that is not the superconductive device. The LED lamps inevitable have the electric resistance so that the injected electrons and holes in the LED lamp lose some amount of the energy by the electric resistance as the Joule Heat. The experimentally determined quantum efficiency is $\eta_q \approx 0.5$ [11]. Two (2) pairs of the electrons and holes must inject to the LED lamp for the generation of one photon. We may calculate the number of the injected electrons into the LED lamp for the illumination of the 1 m^2 room. The calculated number is 2×10^{25} electrons per second to the LED lamp on the dais. The 2×10^{25} electrons per second correspond to the DC electric current of $3 \times 10^6 \text{ A} = 3 \times 10^3 \text{ kA} (= 1.6 \times 10^{-19} \times 2 \times 10^{25} \text{ Coulomb per second})$. The LEDs are solids that inevitably have the electric resistance caused by the thermal perturbation from the thermally vibrating atoms at the lattice sites. The thermally perturbed energy level becomes the bands. You may detect the absorption bands by the spectrometer. The generated Joule Heat in the LED lamps is given by I^2R . The LED lamps are operated with the low applied voltage, 2,8V, but with the huge electric current $3 \times 10^6 \text{ A}$. The power consumption is calculated as $8.4 \times 10^3 \text{ kW} (= 2.8 \text{ V} \times 3 \times 10^6 \text{ A})$. If the LED lamps operated with field scan [12], the power consumption of the LED alone may reduce to the 1.2 kW ($=$

$8.4 \times 10^6 \times 1.5 \times 10^{-4} \text{ W}$) by the field scan for the illumination of the 1 m^2 room. As already described, one compact 20W-HCFL tube may illuminate the 17 m^2 room with the illuminance (330 lm m^{-2}). If the same room is illuminated by the LED lamps, the required LED lamps are calculated as 17 times of the LED lamps on the dais. The LED lamps are the heater of 20 kW ($= 1.2 \times 17 \text{ kW}$) for the illumination by the illuminance (330 lm m^{-2}). The field scan of the LED lamps requires the AC driving circuit. There is no theoretical calculation data based on the η_q . There is a large difference between the commercial advisement and science. Total power consumption of the LED lamps with the field scan adds the W_{drive} of the AC driving circuit. The theoretical and quantitative calculations indicate that the practical LED lamps for the illumination purpose inevitably radiate the huge amount of the heat in the illuminating room. You may compare with the commercialized compact 20W-HCFL tube. The advantage of the commercialized compact 20W-HCFL tube has been concealed with the erroneous luminous efficiency (lm W^{-1}).

The above quantitative calculations clearly indicate that the lighted FL tubes hold the great latent advantage as the unrivaled light source as if the removal or significantly reduction of the unnecessary W_{act} of the external AC driving circuit is made for the lighting source on the given room. For instance, the power consumption of the internal DC electric power generator of the nominal 40W-HCFL tube is below 0.1 W. The active AC power consumption, W_{act} , of the external AC power consumption is 60 W. In this report, we will take a first priority that is the reduction of the unnecessary W_{act} for the light generation of the FL tubes. The W_{act} may down to a few % levels from the present W_{act} by the application of the coil-EEFL tubes [2]. As the reduced W_{coil} to a few % of the present W_{act} , the coil-EEFL tubes may operate with the combination of the solar cells and battery. The remarkable reduction of the W_{act} really contributes to the green energy project on the world.

2. Significant Reduction of W_{act} by Application of Coil-EEFL Tubes

The urgent subject for the improvement of the FL tubes is the significant reduction of the W_{act} of the external AC driving circuit with the long operation life. We cannot take the commercial HCFL tubes for the study on the reduction of the W_{act} . The HCFL tubes essentially have the large W_{act} and short operation life less than 10^3 hours. The large W_{act} is caused by the large induced AC current in the external AC driving circuit. The large induced AC current comes from the large capacitance of the C_{tube} that is formed with the large number of the Ar^{1+} in the lighted FL tube. The unnecessary W_{act} for the lighting of the FL tubes is determined by the large induced AC current from the capacitor C_{tube} . It has found that the W_{act} of the single lighted HCFL tubes may reduce to 0.1 W_{act} of the present FL tube by the conversion to the coil-EEFL tube. Then, we have found the further reduction of the W_{coil} to 0.03 W_{act} by

the parallel connection of 10 coil-EEFL tubes with the single AC driving circuit that has the transformer for the output voltage. The designers of the AC and DC driving circuits of the coil-EEFL tubes may contribute to the remarkable reduction of the ΣW_{coil} . The details are below:

2.1. No Involvement of C_{tube} in AC Operation of Coil-EEFL Tubes

The ordinal FL tubes have the disadvantage that the electrodes of the FL tube pick up the large induced AC current from the huge number of the Ar^{1+} in the Ar gas space of the lighted FL tubes. The number of the Ar^{1+} in the Ar gas space changes with the Ar gas pressures at the given FL tube. The number of Ar^{1+} changes with the diameters and length of the FL tube at the given Ar gas pressure. The large induced AC current results in the large W_{act} of the external AC driving circuit. The size and Ar gas pressures of the commercial HCFL tubes have been determined by the minimization of the W_{act} .

It has found that the external electrodes (EEs) of the AC driving circuit of the lighted coil-EEFL tubes do not pick up the induced AC current from the C_{tube} . The operation conditions of the coil-EEFL tubes are free from the amount of the Ar^{1+} in the lighted FL tube. This is a breakthrough of the study on the FL tubes. The coil-EEFL tubes may contain the high Ar gas pressures without the change of the W_{coil} . The facts described above allow us that the study on the details of the W_{coil} of the coil-EEFL tubes can be made with the coil-EEFL tubes by the conversion from the commercial FL tubes. The results may apply to the W_{coil} of the coil-EEFL tubes that have improved the illuminance with the high Ar gas pressure; e. g., 1×10^4 Pa (= 70 Torr) without change of the W_{coil} .

It is well known that the illuminance (lm m^{-2}) of the FL tubes linearly increases with the Ar gas pressures, but the W_{act} of the external AC driving circuit also linearly increases with the Ar gas pressures. The coil-EEFL tubes can be operated with the high Ar gas pressures, e.g., 10^4 Pa (= 70 Torr) without change the W_{coil} . Therefore, the coil-EEFL tubes may operate the high Ar gas pressures with the same W_{coil} , resulting in the high illuminance (lm m^{-2}) with the same W_{coil} , as if the coil-EEFL tubes have the shallow gap less than 3×10^{-4} m [10].

The coil-EEFL tubes exclusively utilize the cathode and anode of the internal DC electric power generator that forms in the Ar gas space without the injection of the electrons from the external AC driving circuit [2]. The real cathode and anode for the operation of the lighted FL tubes are the volume of the glow lights on the polarized phosphor particles under the EEs on the outer glass wall of the FL tubes [2].

The thickness of the volume of the glow light on the polarized phosphor particles is around 3×10^{-3} m on the polarized phosphor particles under the EEs. The thickness of the glow lights on the polarized phosphor particles determines the preferable diameters of the coil-EEFL tubes. The total thickness of the volume of the glow lights in the given FL tube is 6×10^{-3} m (= $2 \times 3 \times 10^{-3}$ m). The total thickness of the glass

tube is 2×10^{-3} m. The preferable outer diameters of the coil-EEFL tubes are calculated as 8×10^{-3} m $\{(6 + 2) \times 10^{-3} \text{ m}\}$. Practically the outer diameter of the coil-EEFL tubes is narrower than 1.2×10^{-2} m (T-4) for the high illuminance (lm m^{-2}) with the high Ar gas pressures. The coil-EEFL tube wider than 1.2×10^{-2} m also emits the illuminance (lm m^{-2}) higher than that of the commercial HCFL tubes with the high Ar gas pressures. The coil-EEFL tubes with the wider glass tubes require the high Ar gas pressures, preferably 1×10^4 Pa (= 70 Torr), for the increase in the scattering of the moving electrons in the wide positive column for the generation of the lights. Unfortunately, we do not have the proper production facilities for the coil-EEFL tubes in China. With this reason, we take the commercial CCFL tubes produced by other countries for the study on the coil-EEFL tubes.

The coil-EEFL tubes have produced by the conversion from the commercial CCFL tube in the outer diameter of 9.5×10^{-2} m (T-3). The Ar gas pressures in the coil-EEFL tubes are 7×10^3 Pa (= 50 Torr). We have found the commercial cup-EEFL tubes with the same diameter with the CCFL tubes on the market. The operation mechanisms of the cup-EEFL tubes differ from the operation mechanisms of the coil-EEFL tube. The difference comes from the bottom of the cup electrodes of the cup-EEFL tubes. Then, we have an interesting experiment.

The bottom of the cup-EEs of the cup-EEFL tubes vertically sets on the longitudinal direction of the FL tubes. We thought the bottom of the cup-EEs picks up the induced AC current from the C_{tube} in the Ar gas space in the lighted cup-EEFL tubes. The operation conditions of the cup-EEFL tubes have the same with the operation conditions of the CCFL tubes and HCFL tubes. We have thought that the electron sources as the cathode and anode of the cup-EEFL tubes are the same with the coil-EEFL tube. As we cut off the bottom of the cup electrodes, the cup-EEs change to the cylinder-EEs. The cylinder-EEFL tubes significant reduce the W_{syf} to $0.1 W_{\text{act}}$, holding the illuminance. The cylinder-EEFL tubes are equivalent with the coil-EEFL tubes. The experimental results inform us that if the metal electrodes vertically set in the FL tubes at outside or inside of the FL tubes, the electrodes pick up the induced AC current from the C_{tube} . The finding is important information of the study on the FL tubes.

The demerit of the cylinder-EEs is the vacuum break during the operation. The mechanism of the vacuum break of the cylinder EEFL tube is below. There is unavoidably a microscopic air gap between the surface of the glass and metal plate. The air in the gap generates the arc current. The arc current heats up the surface spot of the glass tube to softening temperature. The softening area of the glass wall is under the air pressure at one atmosphere. The softening area generates the through hole under the air pressure. The microscopic hole breaks the vacuum of the cylinder EEFL tube. For the protection of the vacuum break, the cup-EEFL tubes are produced with the borosilicate glass tubes that have the high softening temperatures. But the borosilicate glass tubes do not protect the vacuum break of the cylinder-EEFL tubes. The coil-EEFL tubes completely solved the problem of the vacuum-break by the AC operation.

2.2. Anisotropic Electric Field of Coil-EEs

The distinguish features of the EEs on the outer glass wall is the anisotropic electric field into the defined phosphor particles in the phosphor screen. The electric field from the EEs on the outer glass wall does not extend to the longitudinal direction in either the phosphor screen or glass tube wall and the Ar gas space. The electric field of the EEs on the outer glass wall restricts to the vertical direction from the EEs. The limited phosphor particles under the EEs are synchronously polarized with the AC electric field from the EEs. Accordingly, the W_{coil} of the coil-EEFL tubes is determined by the limited number of the periodically and synchronously polarized phosphor particles under the EEs. The phosphor particles are the polycrystalline particles that belong to the unsymmetrical crystal. The reason is the high transition probability of the luminescent centers. The unsymmetrical crystals easily and largely deform the crystal structure under the electric field. As the consequence of the periodical and synchronous deformation of the phosphor particles under the AC electric field from the EEs, the capacitor C_{coil} forms in the limited number of the phosphor particles in the screen.

The phosphor particles are the polycrystalline particles that contain the plural growing axes in each particle. Naturally, each polycrystalline phosphor particle has many sharp points and sharp line-edges on the surface of the phosphor particles. The sharpness of the points and sharpness of the line-edges on the surfaces of the phosphor particle change with the production conditions of the phosphor particles [12, 13]. The sharpness of the commercial phosphor powders are not controlled by the production process. The phosphor particles that are produced with the well controlled conditions have the sharpness less than $1 \times 10^{-7} \text{ m}$ ($= 0.1 \mu\text{m}$) [2]. The electric field from the sharp points and sharp line-edges of the many polarized phosphor particles are equivalent with the sharp points of the needle electrodes [2]. It should be noted that the surfaces of the commercial phosphor particles heavily contaminated with the deliberately adhered microclusters and deliberately added inorganic binders. The phosphor screen of the coil-EEFL tubes can be made with those commercial phosphor powders, but the coil-EEFL tubes will have a low performance.

As the electric field from the EE is higher than 1.0 kV, the electric field from the sharp points of the polarized phosphor particles suddenly ionize the Ar atoms in the given volume that forms in front of the polarized phosphor particles. The threshold voltage changes with the commercial phosphor particles. The volume of the glow lights forms the internal DC electric power generator in the Ar gas space [2]. The coil-EEFL tubes utilize the volume of the glow light as the cathode and anode in the Ar gas space. Thus, the lights of the coil-EEFL tubes are generated by the excited Ar (and Hg) atoms by the moving electrons between cathode and anode of the internal DC electric power generator. The generation of the lights isolates from the power consumption of the AC

driving circuit. The details of the formation of the internal DC electric circuit are below:

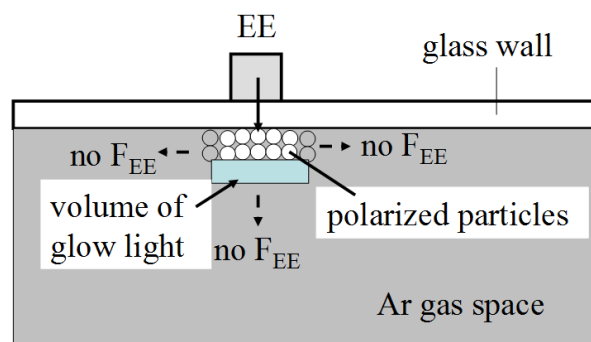

Figure 1. Illustration of anisotropic electric field, F_{EE} , from EE on glass wall of coil-EEFL tube.

Figure 1 illustrates the electric fields from the EE (F_{EE}) on outer glass wall to perpendicular (vertical) direction against the glass wall and to longitudinal (horizontal) direction in the phosphor screen and in the Ar gas space. The anisotropic electric field of the F_{EE} to the vertical direction exclusively polarizes the phosphor particles under the EEs on the glass wall. The electric field from the sharp edges of the polarized phosphor particles ionizes the Ar atoms in front of the polarized phosphor particles. The anisotropic F_{EE} is shielded by the electric charges in the volume of the glow lights, so that the F_{EE} does not extend to the Ar gas space. The shielded EEs never pick up the C_{tube} in the Ar gas space of the lighted FL tube. This can be proved by the change in the positions of the EEs on the glass wall from 1 cm to 38 cm. The W_{EEFL} does not change with positions of the EEs. Furthermore, the DC electric field from the internal DC electric power generator does not pick up the C_{tube} . The application of the coil-EEFL tubes successfully takes away the difficulty of the removal of the C_{tube} in the external AC driving circuit of the lighted FL tubes.

2.3. Optimized Layers of Phosphor Screen

Followings are the optimization of the layers of the phosphor particles in the phosphor screens in the coil-EEFL tubes. One of the prerequisite conditions of the practical coil-EEFL tubes is the polarization of the phosphor particles arranged at top layer of the phosphor screen. As the phosphor particles at the top layer ionize by the electric field from the EEs, the Ar atoms ionize under the electric field from the polarized phosphor particles. If the phosphor particles at the top layer do not polarize under the EEs, the coil-EEFL tubes do not light up. There is the threshold layer for the polarization of the phosphor particles at the top layer on the phosphor screen.

The quantitative study of the effective electric field of the EEs at the top layer of the phosphor screen cannot study on the phosphor screen in the FL tube. The valuable information of the effective electric field from the bottom electrode to the phosphor particles at top layer in the phosphor screen is made by the development of the high resolution of the

images on the phosphor screens of the miniature CRT in the screen size in $1 \times 10^{-4} \text{ m}^2$ [14]. The miniature CRT requires the removal of the electrons on the surface of the phosphor particles arranged at top layer on the phosphor screen by the electrode under the phosphor screen. The number of the layers of the phosphor screens on the electrode is precisely made with the study on the phosphor screens of the miniature CRT [14]. The phosphor particles effectively absorb the strength of the electric field of the electrode at bottom of the phosphor screen. The optimized layers of the phosphor screen for the miniature CRT are a few layers. If the phosphor screen is made by thicker than 7 layers, the electric field from the electrode at bottom does not reach to the phosphor particles at the top layer.

By the referring to the results of the miniature CRT, the EEs on the outer glass wall of the coil-EEFL tubes may extend to the phosphor particles arranged at the top layer on the phosphor screen that is less than 5 layers. The coil-EEFL tubes do not light up with the phosphor screens thicker than 7 layers. If the surfaces of the phosphor particles are contaminated with the residuals of the phosphor production, the phosphor screen in 3 layers in the coil-EEFL tubes do not emit the lights. If the phosphor screen is made with the blend mixture with the phosphor particles and solid-binder particles of the low melting temperatures, the phosphor screen in 3 layers in the coil-EEFL tubes do not light up. You must make the special order to them that the phosphor powders have the clean surface chemically and physically. This is an important point of the study on the coil-EEFL tubes.

The advanced phosphor powders and screening technology request for the production of the coil-EEFL tubes. The conclusion gives a very hard condition to the scientists and engineers who have studied on the FL tubes with the established books and publications of the FL tubes before 2000.

There is another serious problem in the production of the coil-EEFL tubes. The coil-EEFL tubes cannot produce with the poor maintenance of the pumping system, especially contaminated oil-vapor of the rotary pump. You must use the oil less rotary pumps for the preparation of the reliable coil-EEFL tubes.

The scientists and engineers, who are studying on the FL tubes, must accept the new and advanced concepts with the scientific evidences by the material science. The optimized brightness of the coil-EEFL tubes is produced with the 4 to 5 layers of the phosphor particles that have the clean surface physically and chemically. Many commercial HCFL tubes are produced with the phosphor screen thicker than 5 layers of the commercial phosphor particles. The surfaces of many commercial phosphor particles are heavily contaminated. It is said again that the coil-EEFL tubes never light up with the phosphor screens thicker than 7 layers and with the contaminated surface of phosphor particles.

We have the studies of the coil-EEFL tubes by the conversion from the selected commercial CCFL tubes in the outer diameter $9.5 \times 10^{-2} \text{ m}$ (T-3). The tested commercial

CCFL tubes are acceptable for the conversion to the coil-EEFL tubes. However, many CCFL tubes did not convert to the coil-EEFL tubes with the thick phosphor screens and contaminated phosphor particles.

2.4. Positive Column in Ar Gas Space of Lighted FL Tube

The generation of the lights from the phosphor screen of the lighted FL tubes is solely determined by the moving electrons in the Ar gas space. However, the volume of the moving electrons is restricted in the positive volume. We must know the details of (a) the restriction of the volume of the positive column and (b) the generation mechanisms of the lights in the Ar gas space in the positive column of the lighted FL tubes. The lights originate from the excitation of the Hg atoms in the Ar gas space in the positive column. The Ar gas space in the positive column contains the Hg atoms evaporated from the Hg droplets on the phosphor screen. The amount of the evaporated Hg atoms in the positive column depends on the temperatures of the phosphor screen on the inner glass wall of the FL tube. Since the heat source is in the positive column, the temperatures of the phosphor screen are controlled by the depths of the gap between positive column and phosphor screen [10]. The brighter coil-EEFL tubes are produced with the high temperatures of the phosphor screens as possible. The Ar gas space in the gap works as the thermal insulator that surrounds the positive column. The depth of the gap should be minimized for the FL tubes for the heating the Hg droplets on the phosphor screen. The required depth of the gap is less than $3 \times 10^{-4} \text{ m}$. The evaporated Hg atoms in the positive column from the Hg droplets on the phosphor screen are excited by the moving electrons between the cathode and anode of the internal DC electric power generator in Ar gas space. The main problem is that the volume of the Ar gas space, in which the electrons move on, is restricted with the localized electric field from the phosphor screen F_{phos} that has ever discussed in the study on the FL tubes.

The approaching electrons to the phosphor screen receive the strong Coulomb's repulsion from the F_{phos} . The moving electrons cannot reach on the surface of the phosphor screen. The electric conduction in the phosphor screen do not involve in the moving electrons. The electrons only move on in the Ar gas space defined by $F_{\text{vect}} \geq F_{\text{phos}}$. The defined volume is called as the positive column. The FL tubes inevitably have the gap between phosphor screen and positive column. The electrons move on in the superconductive vacuum in the Ar gas space in the positive column between cathode and anode. The moving electrons in the positive column solely ionize and excite the Ar (and evaporated Hg) atoms in the positive column in the lighted FL tube.

The coil-EEFL tubes should be made with the FL tubes that have the gap shallower than $3 \times 10^{-4} \text{ m}$. The shallow depth of the gap is determined from the build-up curve of the lumen (lm) on the control panel of the Ulbricht Sphere [9]. The build-up curve of the lumen (lm) must reach to the saturation level within the time less than 5 minutes. The

study on the phosphor screen of the coil-EEFL tubes must step in the process of the atomic layer of the surface condition of each phosphor particle among 10^{16} particles per gram. Fortunately, we take the selected commercial CCFL tubes on the market for the study on the W_{coil} , although the phosphor screen is not optimized conditions.

3. Incredible Reduction of W_{act} by W_{coil} of Coil-EEFL Tubes

The W_{coil} of the external AC driving circuit of the coil-EEFL tube, which has converted from the commercial CCFL tubes, incredibly reduces to a low level [15]. We have found the commercial CCFL tubes in 3.2×10^{-3} m outer diameter (T-1) with 0.40 m long from Taiwan. The following experiments were made with those CCFL tubes. The Ar gas pressures are at 1×10^4 Pa (≈ 70 Torr). The depth of the gap of the CCFL tubes had estimated as 3×10^{-4} m from the build-up curve of the lumen (lm) on the control panel in the Ulbricht Sphere. We have converted the CCFL tubes to the coil-EEFL tubes by winding of the lead wire (1×10^{-3} m metal diameter) on the outer glass tube with 10 turns. The lead wire is covered with the plastic layer in the thickness 5×10^{-4} m. Figure 2 shows the photographs of the converted coil-EEFL tube (above) and original commercial CCFL tube (bottom).

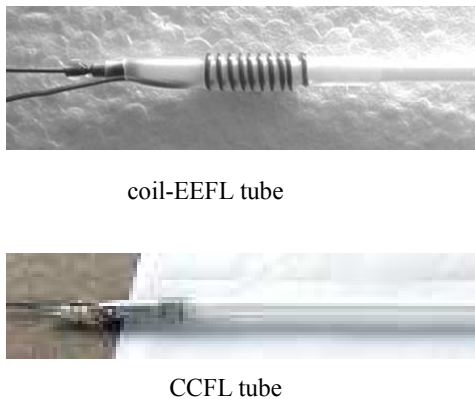

Figure 2. Photographs of coil-EEFL tube (above) and CCFL tube (bottom).

Many commercial HCFL tubes contain the Ar gas pressure at only 931 Pa (7 Torr) with the 3×10^{-3} m depth of the gap. The commercial 40W-HCFL tubes may convert to the coil-EEFL tubes, but the converted coil-EEFL tubes have the low brightness, less than a half of that of the original HCFL tubes. The low brightness of the converted EEFL tubes from the commercial HCFL tubes is caused with (a) the low Ar gas pressure, with (b) the deep gap between positive column and phosphor screen, and (c) small scattering range of the moving electrons from the 3G electron source. If the preparation conditions of the coil-EEFL tubes in wider diameters are optimized, the coil-EEFL tubes may have the high brightness. Unfortunately, we cannot find a laboratory for the study on the coil-EEFL tubes in the diameters wider than 1.0×10^{-2} m in China.

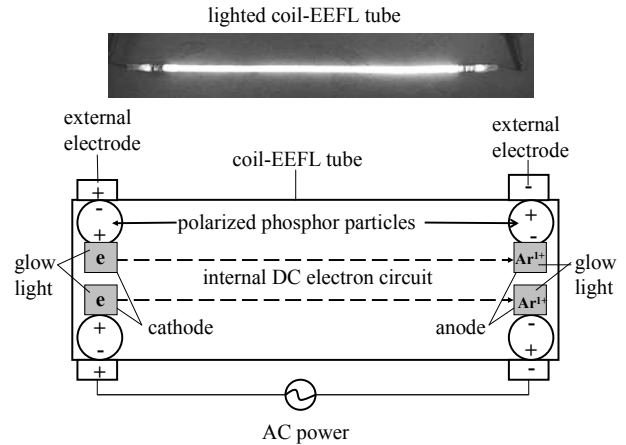

Figure 3. Photopicture of lighted coil-EEFL tube (above) and schematic explanation of formation of internal DC electric power generator by volume of glow lights and moving direction of the electrons between cathode and anode.

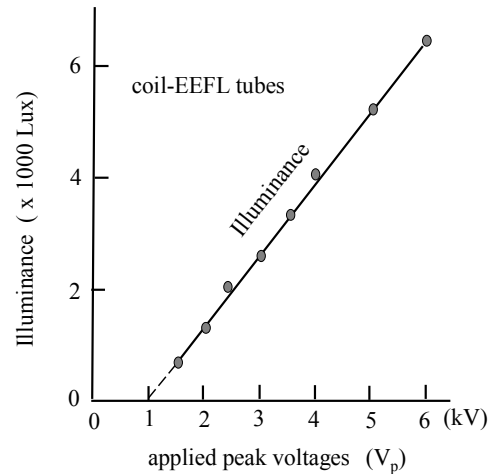

Figure 4. Voltage Dependence Curve of Illuminance of Coil-EEFL Tube.

Figure 3 shows the photograph of the lighted coil-EEFL tube (above) and the illustration of the formation of the internal DC electric power generator in front of the polarized phosphor particles for a half cycle of the external AC driving circuit (below). The electrons move from the cathode to the anode under the F_{vect} of the internal DC electric power generator. The electrons that arrive to the anode recombine with the Ar^{1+} and return to Ar atoms. Figure 4 shows the dependence of the illuminance ($\times 10^3$ Lux) of the coil-EEFL tube as a function of the AC applied voltages (V_p) to the EEs. The illuminance of the coil-EEFL tubes linearly increases with the applied voltages. We recommend the operation of the coil-EEFL tubes with the applied voltages at 5 kV.

3.1. W_{act} of Single Coil-EEFL Tubes

The average W_{act} of the original CCFL tube is 16 W. We will describe first about the coil-EEFL tube that is converted from the CCFL tube. The coil-EEFL tubes and CCFL tubes are operated with the 2 kV_p of the external AC driving circuit with 30 kHz. The W_{coil} of the coil-EEFL tubes do not change with the applied voltages. The change is the brightness of the

coil-EEFL tubes with the applied voltages. The W_{coil} of individual coil-EEFL tubes linearly changed with the winding numbers of the lead wire. With 10 turns, the W_{coil} is 4.5 W. Hence, we may reduce significantly the W_{coil} to $0.28 W_{CCFL}$ $\{= 4.5 \times (16)^{-1}\}$ by the conversion to the coil-EEFL tubes with 10 turns. Figure 5 shows the W_{coil} as the function of the number of the turns of the lead wire on the outer glass wall of the coil-EEFL tube. The lumen (lm) of the coil-EEFL tubes on the control panel of the Ulbricht Sphere do not change with the sizes of the EEs higher than 3 turns ($= 3 \times 10^{-3}$ m width) of the lead wire. The illuminance of the coil-EEFL tubes with the EEs above 3 turns has the same illuminance with the commercial CCFL tubes. For the security, we have made the experiments with the 10 turns.

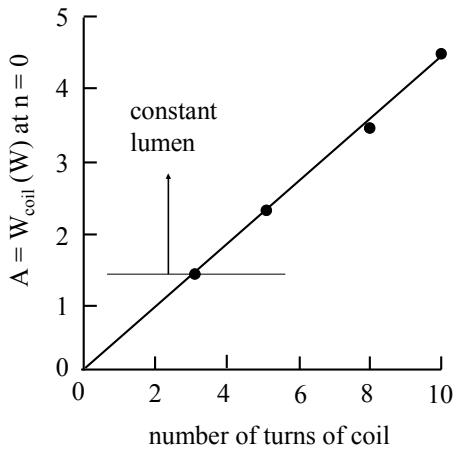

Figure 5. A-values of ΣW_{coil} -curves in parallel connection of coil-EEFL tubes as function of number of turning coil on coil-EEFL tube.

3.2. Further Reduction of W_{coil} by Parallel Connection with Single AC Driving Circuit.

The coil-EEFL tubes and CCFL tubes allows the parallel connection with the single AC driving device. Each coil-EEFL tube in the parallel connection has the equal illuminance. The results indicate the well control of the capacitances C_{phos} of the coil-EEFL tubes and the C_{tube} of the CCFL tubes. The commercial HCFL tubes have the large variation of the C_{tube} with the large variation in the amount of the BaO particles on the W-filament coils. The commercial 40W-HCFL tubes do not light up with the parallel connection. The variation in the capacitances of the C_{tube} in the commercial HCFL tubes comes from the misunderstanding of the role of the BaO particles on the W-filament coils.

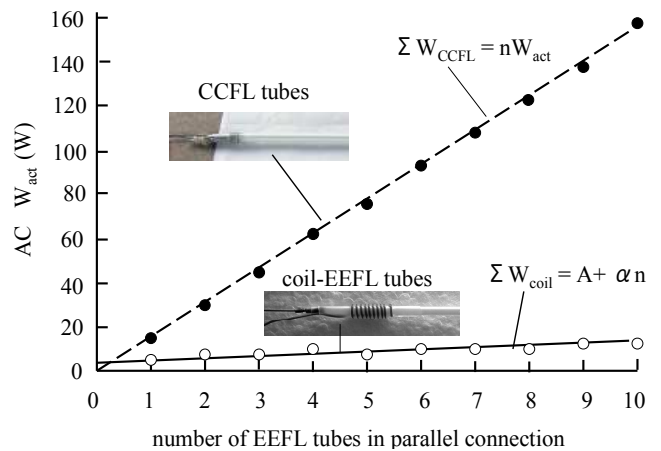

Figure 6. Experimental curves of 10 CCFL tubes (black circles) and 10 coil-EEFL tubes in parallel connection with single AC driving circuit that supplies 2.5 kV with 30 kHz.

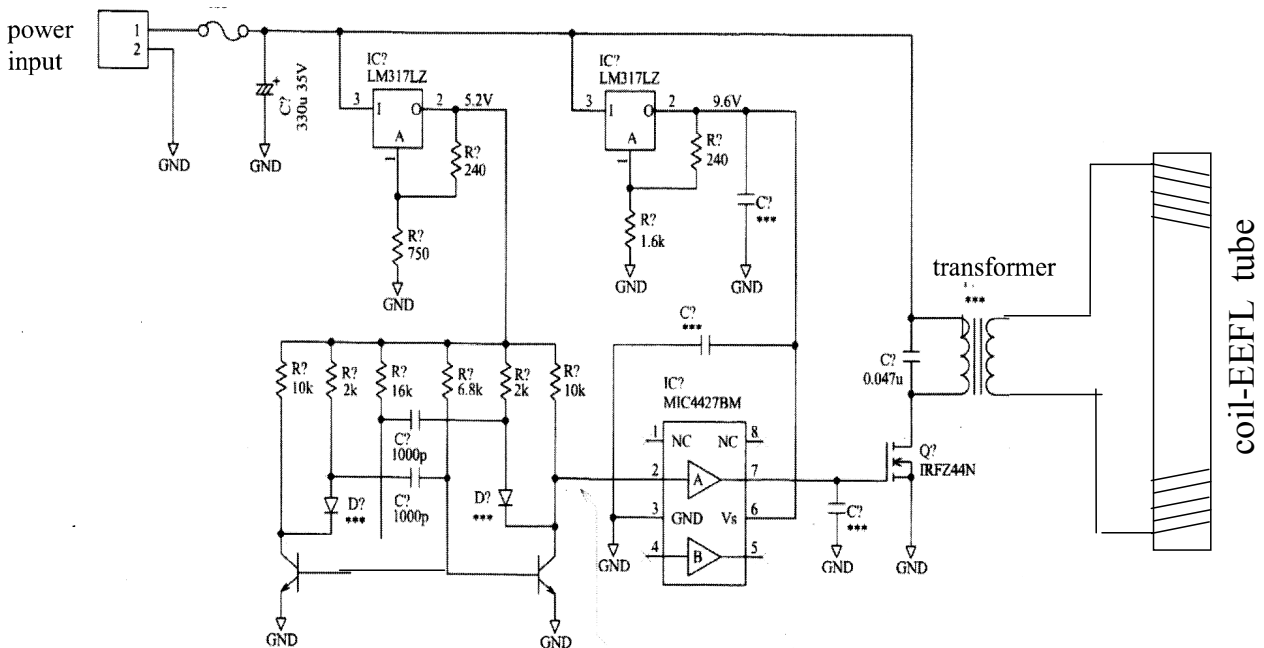

Figure 7. Circuit diagram of AC driving device with transformer for output voltage.

Figure 6 shows the experimental curves of the ΣW_{coil} of the 10 coil-EEFL tubes in the parallel connections with the single AC driving circuit at 3 kV. In Figure 6 also contains the ΣW_{CCFL} of the 10 CCFL tubes with the single AC driving circuit for the CCFL tubes. The coil-EEFL tubes have the EEs with 10 turns of the coil wire on the outer glass wall. The circuit diagram of the external AC driving device for the coil-EEFL tubes has the transformer for the output voltage as shown in Figure 7. All examined FL tubes emit the equal illuminance. However, there are the large differences in the curves between W_{coil} and W_{CCFL} . The ΣW_{CCFL} of the n-CCFL tubes is given by $n \cdot W_{CCFL}$. The ΣW_{CCFL} with 10 CCFL tubes is 160 W. There is no advantage for the parallel connection of the CCFL tubes.

On the other hands, the C_{phos} of the coil-EEFL tubes with the coil-EEs in 10 turns has the different story. The capacitances of the C_{phos} of the coil-EEFL tubes relate to the number of the polarized phosphor particles under the EEs. The total capacitance of the n- C_{phos} in the parallel connection in Figure 6 is not expressed by $n \times C_{phos}$. The reason will describe in later. Anyhow, we have experimentally found a new way that is the significant reduction of the ΣW_{coil} of the coil-EEFL tubes in the parallel connection from Figure 6. The ΣW_{coil} of the external AC driving circuit for the coil-EEFL tubes in the parallel connection is expressed by

$$\Sigma W_{coil} = A + \alpha n \tag{1}$$

Where A is a constant that is determined by $n = 0$ and the unit of the A is given by watt. The α is the slop of the curve and is given by watt per coil-EEFL tube. The curve in Figure 6 has $A = 4 \text{ W}$ and $\alpha = 1.0 \text{ W per tube}$. With the small A value and small α value, the ΣW_{coil} with 10 coil-EEFL tubes (with the EEs of 10 turns) gives only 14 W $\{= (4 + 10) \text{ W}\}$, that is only $0.09 W_{CCFL} (= 14 \times 160^{-1})$ of the 10 CCFL tubes. The coil-EEFL tubes have a great advantage in the power consumption with the parallel connection with the single driving circuit. As the EEs of the coil-EEFL tubes are made with the 5 turns, the ΣW_{coil} is 7 W that is $0.04 W_{CCFL}$.

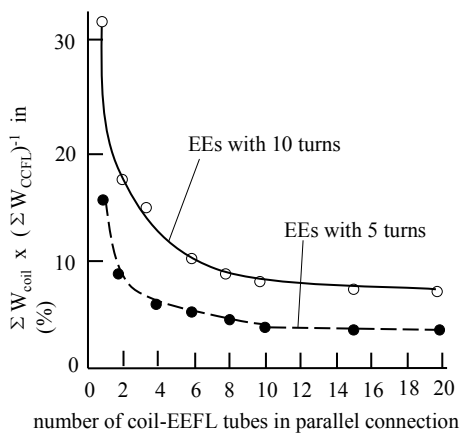

Figure 8. Experimental curve of $\Sigma W_{coil} \times (\Sigma W_{CCFL})^{-1}$ as function of number of parallel connection of coil-EEFL tubes.

We have studied the change in the reduction rate of the

$\{\Sigma W_{coil} \times (\Sigma W_{CCFL})^{-1}\}$ up to 20 coil-EEFL tubes. Figure 8 shows the experimental curves of the reduction rate of the $\{\Sigma W_{coil} \times (\Sigma W_{CCFL})^{-1}\}$ with the EEs of the 10 turns and 5 turns, respectively. The reduction rate of the $\{\Sigma W_{coil} \times (\Sigma W_{CCFL})^{-1}\}$ curves is sharply decreased with the small number of the parallel connections below 5 coil-EEFL tubes. The reduction rate approaches to the constant with 10 coil-EEFL tubes. Above 10 coil-EEFL tubes, the curves are nearly constant. From the results in Figure 8, the preferable number of the parallel connection of the coil-EEFL tubes are higher than 10 coil-EEFL tubes for the saving of the electric AC power consumption of the AC driving circuit. The W_{coil} of the coil-EEFL tubes does not change with the lengths of the FL tubes. But the brightness sometimes changes with the lengths of the coil-EEFL tubes as if the arrangement of the phosphor particles in the screen is not optimized. The structure of the phosphor screen will report separately. The parallel connection of the 20 coil-EEFL tubes, and more, in the outer diameter $1.3 \times 10^{-2} \text{ m}$ (T-4) gives the advantage for the large illumination room and backlights of the large LCD panels with the AC power consumption after the optimization of the phosphor screens and the external AC driving circuits.

The practical lighting source that has the less electric energy and high illuminance may be produced with the bound coil-EEFL tubes higher than 10 EEFL tubes that are in the parallel connection. The new lighting source may be made by setting of the bound coil-EEFL tubes in the parallel connection in a opaque glass tube in the wider diameters or in a flat and thin opaque box, like as the compact-20W FL tubes in the opaque cover [9]. The practical application of the coil-EEFL tubes in the parallel connections in the cover as the lighting source remains for the future study.

We have a question about the results of the curve of the parallel connection of the coil-EEFL tubes shown in Figure 6. We have found the very interesting results in the operation of the coil-EEFL tubes in the parallel connection. As the external AC driving device does not have the transformer at output voltage, the ΣW_{coil} of the coil-EEFL tubes is a simple function of the number of the individual W_{coil} ; $\Sigma W_{coil} = n \times W_{coil}$. Figure 9 shows the curve of $\Sigma W_{coil} = n \times W_{coil}$ with the black circles. ΣW_{coil} of 10 coil-EEFL tubes that are operated with the AC driving circle without the transformer is 45 W $(= 4.5 \text{ W} \times 10)$.

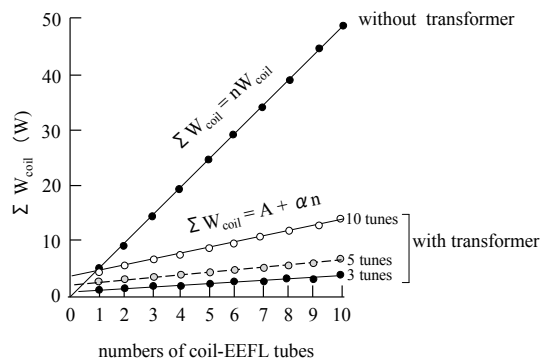

Figure 9. Total W_{coil} of 10 coil-EEFL tubes with different AC driving circuits; with and without transformer at output of voltage.

As the external AC driving circuit has the transformer as shown in Figure 7, the curve of the ΣW_{coil} drastically changes from the $n W_{\text{coil}}$. As the coil-EEFL tubes in the parallel connection are operated with the AC driving circuit shown in Figure 7, the ΣW_{coil} follows with Eq (1). The curves in Figure 9 with the transformer shown in Figure 7 are the different A values of the Eq (1). The A-values of the Eq (1) are changed with the number of the turns of the lead wire on the outer glass wall of the coil-EEFL tubes. Figure 9 shows the A values with the 10 turns, 5 turns and 3 turns, respectively with the transformer in Figure 7. The A values are linearly changed with the number of the turns of the lead wire on the outer glass wall of the EEFL tube. The slope of the three curves have same $\alpha = 1.0$.

Fortunately, we temporarily have the different AC driving circuit that has the complicated transformer at the output of the voltage of the AC driving circuit with 3 kV and 50 kHz. The coil-EEFL tubes in the parallel connection have the same A values but the different slope as $\alpha = 0.3$, instead of 1.0 in Eq. (1). The ΣW_{coil} of the 10 coil-EEFL tubes with the EEs with the 5 turns is only 7 W ($= 4 + 3$ W) that is $0.04 W_{\text{CCFL}} \{= 7 \text{ W} \times (160 \text{ W})^{-1}\}$. The ΣW_{coil} with 20 coil-EEFL tubes is 10 W ($= 4 + 6$ W). The individual coil-EEFL tubes have the same illuminance. Consequently, you may have the 20 times of the illuminance with 10 W of the AC power consumption. The 20 coil-EEFL tubes in the parallel connection can be operated with the combination of the solar cell and battery. Unfortunately we do not have the circuit designer around us. A very interesting subject that the remarkable reduction of the ΣW_{coil} of the coil-EEFL tubes in the parallel connection remains for the future study by the circuit designers.

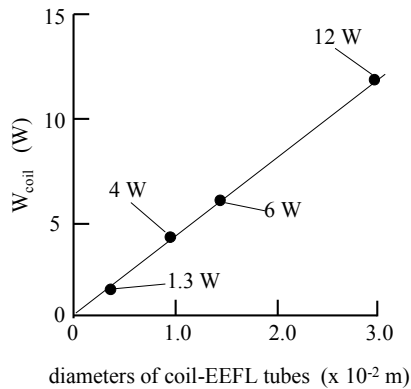

Figure 10. W_{coil} at $n = 0$ of coil-EEFL tubes in different outer diameters of coil-EEFL tubes.

We have the preliminary studies on the A-values of the different diameters of the coil-EEFL tubes with 5 turns for the future study. Figure 10 shows the experimental results. The A-values have the linear function of the outer diameters of the FL tubes. If the outer diameter of the coil-EEFL tubes is 3.2×10^{-2} m (T-10), the ΣW_{coil} of the coil-EEFL tubes is given by $\Sigma W_{\text{coil}} = 12 \text{ W} + \alpha n$ with the circuit in Figure 7. The ΣW_{coil} of the 10 coil-EEFL tubes is calculated with $22 \text{ W} \{= 12 + 10) \text{ W}\}$ that is $0.04 W_{\text{act}}$ of the 40W-HCFL tubes with

the inverter. Figure 11 shows the photopicture of the lighted 10 coil-EEFL tubes that have converted from the commercial 40W-HCFL tubes that have selected from a store. The illuminance of the individual coil-EEFL tubes converted from the commercial 40W-HCFL tubes is about a half of the 40W-HCFL tubes. Total illuminance of the 10 coil-EEFL tubes is nearly 5 times of the original 40W-HCFL tube. We have 5 times of the illuminance with the one third of the AC power consumption. The low illuminance of the coil-EEFL tubes is caused with (a) the low Ar gas pressure at 931 Pa (7 Torr) and (b) the deep depth ($\sim 1 \times 10^{-3}$ m) between phosphor screen and positive column of the lighted HCFL tubes.

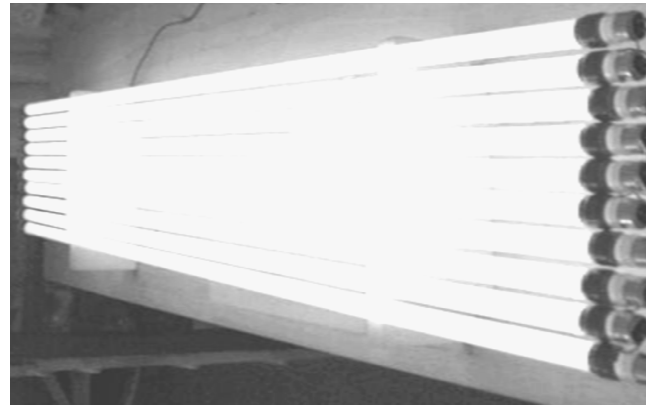

Figure 11. Photograph of lighted 10 coil-EEFL tubes in outer diameter 3.2×10^{-2} m with 1.2 m long in parallel connection with single AC driving device that supplies 4 kV with 50 kHz to the electrodes of EEs.

The both W_{coil} and the light intensity from the phosphor screen of the coil-EEFL tubes do not change with the distance between EEs on the FL glass tubes. The experimental results evidently indicate no involvement of the C_{tube} in the lighted coil-EEFL tubes. We have not optimized the performance of the coil-EEFL tubes in this study. The remained subject of the coil-EEFL tubes is the control of the change in the phosphor screen. The optimization of the coil-EEFL tubes remains for the future study for some else. If the coil-EEFL tubes are operated with the external DC electric circuit, the W_{coil} will be zero [2]. The external DC electric circuits may be produced with the application of the piezoelectric transformer. The completion of the study on the unrivaled coil-EEFL tubes as the lighting source will be made by someone else in the near future. The author wishes it.

4. Conclusion

The lighted FL tubes are operated with the disparate circuits that are (a) the external AC driving circuit and (b) the internal DC driving circuit, although the FL tubes are operated with the single AC driving circuit. The lights of the FL tubes are generated by the excitation of the Ar and Hg atoms with the moving electrons in the internal DC driving circuit. The external AC driving circuit is closed with the induced AC current, not flowing electrons, from the capacitor C_{tube} . The role of the external AC circuit is the conjugation with the internal DC electric circuit by the electric field from the

electrodes of the lighted FL tubes. So far as the electrodes of the external AC driving circuit vertically set at either outside or inside of the ends of the FL tubes, the electrodes inevitably pick up the large AC induced current from the capacitor C_{tube} . The induced AC current at the electrodes determine the large W_{act} of the external AC driving circuit. The large W_{act} does not involve in the generation of the lights in the lighted FL tubes. The reduction of the W_{act} of the external AC driving circuit is the urgent subject for the energy saving of the lighted FL tubes. This report has aimed the significant reduction of the W_{act} of the external AC driving circuit by the application of the coil-EEFL tubes.

It has found that coil-EEFL tubes significantly minimize the W_{coil} with no involvement in the C_{tube} in the operation. The single coil-EEFL tube may reduce to 0.3 W_{act} . The further reduction of the W_{coil} is made with the parallel connection of the coil-EEFL tubes with the single AC driving circuit with the transformer at output. The ΣW_{coil} of 20 coil-EEFL tubes in the parallel connection under the single AC driving circuit will be down to 0.03 ΣW_{act} of the commercial HCFL tubes. The illuminance (lm m^{-2}) of the coil-EEFL tubes is determined by the operation conditions of the internal DC electric power generator that forms in the Ar gas space. The results suggest us that the coil-EEFL tubes, that have the astronomical quantum efficiency, are the unrivaled light source with the very small W_{coil} over the solid lighting sources, such as the LED lamps. The study on the optimizations of the coil-EEFL tubes remains for a future study by someone else.

Acknowledgement

The author wishes to express his great appreciation to Dr. Takao Toryu for his deliberate instruction of this project.

References

- [1] L. Ozawa and Y. Tian, "Coexistence of disparities of external AC driving circuit and internal DC electron circuit in operation of fluorescence tube", *J. China Ill. Eng. Soc.*, 6, 19-30, 2011
- [2] L. Ozawa, "Development of prototype of coil-EEFL tubes", *Science Research*, 3(4), pp 220-229, 2015
- [3] F. M. Penning, "Electrical discharges in gases, The Macmillan Company, New York, 1957
- [4] J. F. Waymouth, "Electric Discharge Lamp", MIT Press, 1971
- [5] Handbook of "Electric Discharge lamps", Japanese Institute of Electric Engineers, 1973
- [6] American Vacuum society Classics, (1) The fundamental data on electrical discharge gases, (2) Field emission and field ionization, (3) Vacuum technology and space simulation, (4) The physical basics of ultrahigh vacuum, (5) Handbook of electron tube and vacuum techniques, (6) Vacuum sealing techniques, and (7) Ionized gases, American Institute of Physics, 1993
- [7] L. Ozawa and Y. Tian, "A new 4G electron source for Fluorescent tubes, *J. China Illu. Eng. Soc.*, 7, pp 58-65, 2012
- [8] L. Ozawa and Y. Tian, "calculation of quantum efficiency of phosphor screens in CRTs and FL tubes, *Korean J. Information display*, 11, pp 128-133, 2010
- [9] L. Ozawa, "Illuminance (lm m^{-2}) of compact 20W-HCFL tube", *Science Research*, 3(4), pp 170-179, 2015.
- [10] L. Ozawa, "illuminance of FL tubes controlled by depth of gap between positive column and phosphor screen", *Science Research*, 3(2), pp 93-104, 2015
- [11] L. Ozawa and T. Yakui, [Restriction of solid lighting sources in practical use], *J. China Illu. Eng. Soc.*, 6, pp57-64, 2011
- [12] L. Ozawa, "Figure 3-2 and Table 3-1 in Cathodoluminescence and Photoluminescence, theory and practical application", CRC Press, Taylor & Francis, Group, Boca Raton, 2007
- [13] L. Ozawa, "Cathodoluminescence", Kodansha, Tokyo, Japan, 1990
- [14] L. Ozawa and K. Oki, "307,200 pixels cm^{-2} resolution phosphor screen in monochrome CRT", *Materials chemistry and Physics*, 60, 274-281, 1999
- [15] L. Ozawa and M. Kato, "Coil-EEFL tube", China Pat. 102,067,276, May 18, 2011; and Japan Pat. 4,923,110, Feb. 10, 2012
- [16] L. Ozawa and Y. Tian, "Remarkable enhancement of luminance of coil-EEFL tubes setting in vacuum-sealed sheath tube", *J. China Ill. Eng. Soc.*, 8, 105-113, 2013.